

## Model FGM-550 Fluxgate Magnetometer

### A Universal Magnetometer for use with Magnetic Research Type FM Fluxgate Sensors

#### Description

The Model FGM Magnetometer is a relatively simple circuit incorporating three integrated circuits, two transistors, 19 resistors and four capacitors on a three and one-half inch by five and one-half inch circuit board. A resonating or "tuning" capacitor is supplied with the fluxgate sensor. The magnetometer requires a  $\pm 5$  volt dc supply and a dc voltmeter – an analog or digital multimeter will serve nicely.

The magnetometer can be built on a standard pre-punched Fiberglass circuit board – the .062" thick type with .042" diameter holes on .100" centers is recommended. If desired, a printed circuit board can be fabricated using the lead layout provided with this data. The parts locations are not critical, but the general layout shown here should be followed.

If the instrument is to be operated as a portable unit using a 9 volt or 12 volt battery, the Bipolar Regulated Power Supply, described in the *Magnetic Measurements Handbook*, may be added. In addition, for enhanced linearity and lower sensor temperature coefficient effects the Simple Integrator Circuit, also described in the handbook, may easily be added to the circuit. Incorporating the Integrator will require a slightly larger circuit board – or, a small board containing the Integrator components may be added to the 3.5" by 5.5" main board.

#### Fabrication

The required components may be easily mounted using Vector type T42-1/M terminals (Digi-Key p/n V-1069). – approximately sixty of the push-in terminal are required. Good quality i.c. sockets are recommended. One 16-pin socket and two 14-pin sockets are required. In addition, it is recommended that an 8-pin i.c. socket be used for insertion of the two MOSFET transistors.

Number 24 or number 26 gauge buss wire may be used for component interconnections. Number 20 gauge buss wire is recommended for the +5 volt main buss, the main common buss and the main -5 volt buss leads. – see the circuit board illustrations. Care should be exercised if the MOSFET transistors are soldered into the circuit; leads should be left full length and heat-sink clips should be used while soldering. If an i.c. socket is used for mounting the transistors the foregoing precautions can be disregarded.

A four terminal connecting block for attaching the sensor leads is illustrated. This can be expanded to a six terminal block, if desired, to provide screw-in connections for the indicating meter, in lieu of the Vector terminals indicated on the illustrations. A parts vendor, his stock numbers and advertised prices are included for ease of identification. Substitution of parts may be made providing they have similar specifications.

A type DG211 analog switch has been substituted in place of the DG201 specified with no apparent change in circuit operation. However, the slightly higher cost DG201 is recommended. If desired, two LM741 i.c.s may be used instead of the single package LM747. This, however, would require changes in the board layout.

#### Oscillator

A CD4047 multivibrator is used as the square wave generator. This i.c. has a secondary square wave output which has a frequency exactly twice that of the oscillator frequency. This output is used as the synchronizing signal for the synchronous detector.

A combination of two fixed resistors and a variable trimpot is used as the resistive components of the RC circuit. Two fixed values are used in order to enable a low value trimmer to be used for R1. A single resistor can be used, if desired, in lieu of the two series resistors.

A capacitor of 120 pF was selected as the value of C1 for the 10 kHz frequency required by the FM-340 and FM-400 fluxgate sensors. Using this capacitor value a total resistance (R1+R2+R3) of 166.66K is required. Any reasonable combination of R and C may be used to generate the required frequency.

Substituting a capacitor of 160 pF will enable a frequency of 7.5 kHz to be generated (for driving the Type FM-210 Sensor) using the same resistance value of 166.66K ohms. Here again, any reasonable values of R and C may be used. The 4.7 uF tantalum capacitor (C2) is required in order to prevent high-level square waves from the oscillator from getting into the synchronous detector and causing a large zero offset.

The frequency generated and the RC values required may be determined by using the following equation:

$$f = \frac{1}{0.005(RC)}$$

where:

f = frequency in kHz  
 R = resistor value in ohms  
 C = capacitor value in uF

#### Driver

Zetex ZVP and ZVN series MOSFET transistors are used to supply sufficient power to drive the fluxgate core well into saturation. Other manufacturer's components may be used providing they can handle the current required. The combination of L1, C4 is a matching network for the sensor. The one-ohm resistor (R6) enables the current wave form through the sensor primary to be observed and its amplitude to be measured. The value was selected so that the emf developed across the resistor will be a direct indication of the current; i.e. 0.1 volt will indicate a current of 0.1 ampere.

The wave form, as observed on an oscilloscope, should appear as illustrated below:

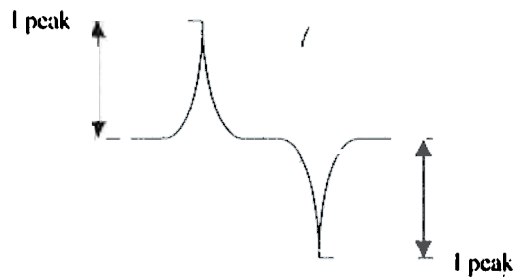

#### Synchronous Detector

This circuit is also referred to as a *synchronous demodulator*. It uses an analog switch and an operational amplifier as the active circuit. The analog switch is driven at a rate of 15 kHz when the oscillator frequency is 7.5 kHz (for the FM-210 Fluxgate), and at 20 kHz when the oscillator runs at 10 kHz (for the FM-340 or FM-400).

The synchronization effect will cancel out most noise and all frequencies other than the second harmonic signal generated by external magnetic fields affecting the sensor. The output from IC-2A, at TP-5, will be a dc signal having an amplitude directly proportional to the level of the magnetic field. A DG201A analog switch is recommended as the switching component. A less expensive DG211 has also been used successfully. This circuit has little or no offset – and any small amount that it might have can be easily nullified by use of the DC Amplifier Zero Adjust control. Note: in the interests of good engineering practice it is recommended that the input pins of the unused sections of the DG210A or DG211A be grounded (pins 8, 9 and 16).

#### DC Amplifier

The DC Amplifier (IC-2B) uses one-half of the LM747 i.c. The values of the feedback resistance (R12, R13) will depend upon the type of Fluxgate Sensor used. Gain may range from about 1.5 to 3 for the FM-210 and FM-340 fluxgates to between 5 and 8 for the FM-400 sensor. The variable component (R12) may be a 10KΩ or 5KΩ multi-turn trimpot with the balance of the required total resistance made up in the fixed component (R13). For best t.c. and stability it is advised that the fixed resistor value be greater than that of the trimpot. The gain can be adjusted so that 1 oersted (gauss) = 1 volt dc output, or 0.1 oersted equals 1 volt, or whatever ratio is desired. A switch and appropriate resistors can be used in lieu of a single fixed resistor in order to enable a multi-range magnetometer to be achieved.

The Test Data sheet normally supplied with the FM-Series Fluxgates indicates the gain that was required for that sensor when the dc amplifier output was 1 volt for a sensed field of 1 oersted.

Recently a letter was posted on the "Public Seismic Network" that gave several sources of information on how to build a magnetometer. One of the sources was a book, "The Magnetic Measurements Handbook" by J.M. Janicke who lives in Butler, NJ a nearby town I pass through often. On my way to Home Depot I stopped by to visit Mr. Janicke and buy a copy of his book. He is a retired electrical engineer who worked much of his life in the aerospace industry designing magnetic instruments. He has written his handbook for amateurs interested in building homemade magnetic devices. You can find out much more about the interesting projects in his book at his web site, << <http://www.webspan.net/~magres/> >>. With his permission I have reproduced below his schematic and complete details on how to build a flux gate magnetometer. There is nothing critical about the design so there is no need to follow it slavishly. The easiest way is to buy all the parts from Digi-Key but Radio Shack parts would be a satisfactory substitute for some items. Mouser << <http://www.mouser.com/> >> or call (800) 346 6873, is also a good source of parts and they have no minimum order requirement. It might be a good idea to solder the ICs and transistors directly into the circuit board but don't try this unless you have a good soldering iron that is adjustable and can be set to a suitable low temperature. Radio Shack's Butane gas soldering iron set on its very lowest temperature setting is suitable for soldering ICs directly into a circuit board without cooking them. By not using sockets you can avoid possible future problems with poor connections in any homemade electronic device. If you want to remove an IC it is easy to do with Radio Shack's copper desoldering braid. The braid is also handy for redoing sloppy soldering jobs. No amateur should be without it. If you have any questions or run into trouble, Mr. Janicke will be glad to help you. His email address is << [magres@webspan.net](mailto:magres@webspan.net) >>.

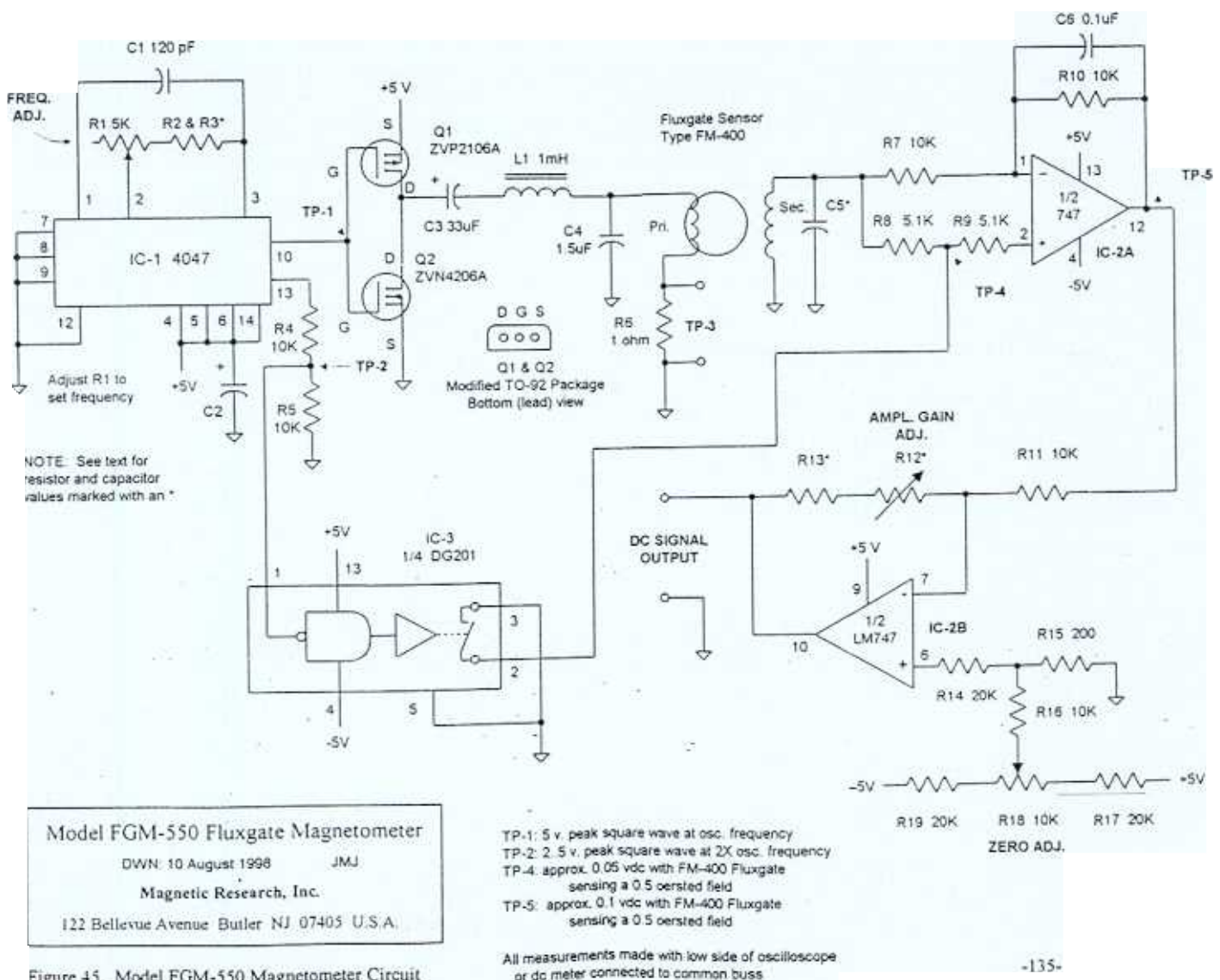

Figure 45. Model FGM-550 Magnetometer Circuit

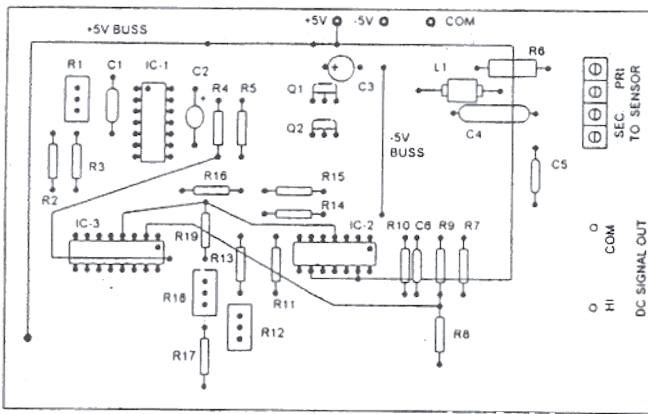

Figure 43. FGM-550 Magnetometer Circuit Board - top view

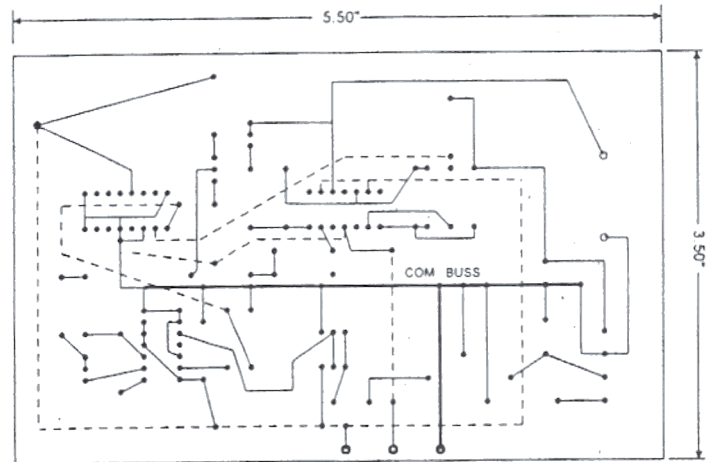

Figure 44. FGM-550 Circuit Board - bottom view. Note: dashed lines indicate top side leads.

If, for example, the data sheet indicates that a gain of 2.1 was required then a total resistance of 21K $\Omega$  is used for the feedback resistor (R12 plus R13). Resistor values in the zero-balancing network (R14, R15 and R16) were selected to provide easy compensation for any offset in the dc amplifier.

#### Setup and Operation

After completion of the board the magnetometer can be checked out for initial operation by following the steps outlined below, after connecting the appropriate Fluxgate Sensor.

1. Apply power to the magnetometer; allow 3 minute warm-up.
2. Check for proper frequency at TP-1; adjust as required.
3. Observe the wave form at TP-3 (across R6).
4. Connect a dc meter across the DC Signal Output terminals.
5. Temporarily connect a short-circuit across C5. Adjust the Zero-Adj. trimmer for zero indication on the meter. Remove short circuit.
6. Using a Helmholtz Coil or Calibration Solenoid, as per the instructions in *The Magnetic Measurements Handbook*, adjust amplifier gain trimpot for appropriate meter indication commensurate with the applied magnetic reference field. Resistor selection may be required to obtain required gain.

#### Parts List

Symbol	Description	D-K p/n	Price(\$)
C1	120 pF $\pm 5\%$ 50 vdc. polypropylene	P3121	0.25
C2	4.7 uF 25 vdc. tantalum	P2047	0.55
C3	33 uF 25 vdc electrolytic	P5150	0.22
C4	1.5 uF $\pm 10\%$ 100 vdc polyester	EF1155	0.91
C5	Supplied with sensor		
C6	0.1 uF $\pm 10\%$ 50 vdc met. film	P4525	0.15
IC-1	CD4047BCN multivibrator	CD4047BCN	1.00
IC-2	LM747CN Hi-perf. dual op-amp	LM747CN	1.00
IC-3	DG201A Analog Switch	DG201ACJ	4.40
L1	mH choke	M7102	1.73
Q1	Zetex ZVP2106A MOSFET	ZVP2106A	1.23
Q2	Zetex ZVN4206A MOSFET	ZVN4206A	1.02
R1	5K $\Omega$ 25-turn trimpot	3296W-502	2.83

Symbol	Description	D-K p/n	Price(\$)
R2/3	See text - $\pm 1\%$ metal film resistors		0.10
R4	10K $\Omega$ $\pm 1\%$ 1/4 watt metal film	10.0KXBK	0.10
R5	10K $\Omega$ $\pm 1\%$ 1/4 watt metal film	10.0KXBK	0.10
R6	1 $\Omega$ $\pm 5\%$ 1 watt metal oxide	1.0W-1	0.05
R7	10K $\Omega$ $\pm 1\%$ 1/4 watt metal film	10.0KXBK	0.10
R8	5.11K $\Omega$ $\pm 1\%$ 1/4 watt metal film	5.11KXBK	0.10
R9	5.11K $\Omega$ $\pm 1\%$ 1/4 watt metal film	5.11KXBK	0.10
R10	10K $\Omega$ $\pm 1\%$ 1/4 watt metal film	10.0KXBK	0.10
R11	10K $\Omega$ $\pm 1\%$ 1/4 watt metal film	10.0KXBK	0.10
R12	Trimpot 25-turn cermet, see text	Type 3296W	2.83
R13	See text - $\pm 1\%$ 1/4 watt metal film		0.10
R14	20K $\Omega$ $\pm 1$ 1/4 watt metal film	20.0KXBK	0.10
R15	200 $\Omega$ $\pm 1\%$ 1/4 watt metal film	200XBK	0.10
R16	10K $\Omega$ $\pm 1\%$ 1/4 watt metal film	10.0KXBK	0.10
R17	20K $\Omega$ $\pm 1\%$ 1/4 watt metal film	20.0KXBK	0.10
R18	10K $\Omega$ 25-turn trimpot	3296W-103	2.83
R19	20K $\Omega$ $\pm 1\%$ 1/4 watt metal film	10.0KXBK	0.10

Sensor, Magnetic Research Type FM see data sheets

Integrated circuit sockets: 8-pin = \$0.40; 14-pin = \$0.70

16-pin = \$0.85

Circuit board: 3.5" x 5.5" = \$3.00

Vector Micro-Klip<sup>®</sup> terminals, 60 required = \$0.05 ea. NOTE: an appropriate hand insertion tool is recommended for inserting the Vector Type T42-1 pins into the circuit board.

Estimated total electronic parts = \$29.00 (not incl. Fluxgate Sensor)

Digi-Key Corp. 701 Brooks Ave. South

Thief River Falls MN 56701-0677

(Tel: 800-344-4539) is a suggested source and their part numbers and prices are included because they have all of the necessary components. However, any source such as Newark Electronics or Radio Shack may be a satisfactory alternate.

**Magnetic Research, Inc.**

122 Bellevue Avenue Butler NJ 07405 U.S.A.